

2116-267#-1200 Block Downconverter 26.5534 - 26.8534 to 1200 ± 150 MHz

The 2116-267#-1200 Block Downconverter converts 26.5534 - 26.8534 GHz to 1200 ± 150 MHz with a local oscillator at 25.5034 GHz. Front panel LEDs provide indication of DC power, external 10 MHz, and PLL alarm. The RF to L-band gain is -5 dB. Connectors are 2.92mm female for the RF and BNC female for the L-Band and external reference input and reference output. A three-way switch controls which 10 MHz reference is being used. In the INT position, the internal reference is used, in the EXT position, the external reference is used, and in the AUTO position, the internal reference is used unless a +3 dBm ± 3 dB, 10MHz reference signal is connected to the external reference input. It is powered by a 100-240 ±10% VAC power supply, and mounted in a 1 3/4" X 19" X 14" rack mount chassis.

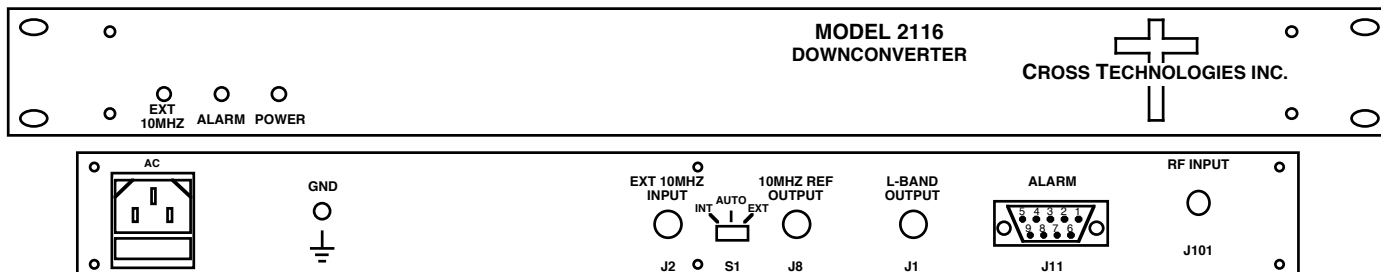

Front and Rear Panels

EQUIPMENT SPECIFICATIONS*

Input Characteristics

Impedance/Return Loss 50Ω/14 dB
 Frequency 26.5534 - 26.8534 GHz
 Noise Figure, Max. 20 dB max gain
 Input Level range -20 to -10 dBm

Output Characteristics

Impedance/Return Loss 50 Ω /15 dB
 Frequency 1200 ± 150 MHz
 Output Level Range -25 to -15 dBm
 Output 1 dB compr. -5 dBm

Channel Characteristics

Gain at Fc -5 dB ±2 dB
 Image Rejection > 60 dB, min
 Spurious, Inband SIGNAL RELATED<-50 dBC in band, -15 dBm out; SIGNAL INDEPENDENT,<-60 dBm
 Spurious, Out of band <-50 dBm, (0.5-1.04 and 1.36-2.0 GHz Out)
 Intermodulation <-50 dBC for two carriers at 4 MHz spacing, each at -25 dBm out
 Frequency Response ±1.5 dB, 1200 ± 150 MHz out; ± 0.5 dB, 40 MHz BW
 Frequency Sense Non-inverting

LO Characteristics

LO Frequency 25.5034GHz
 Frequency Accuracy ± 0.01 ppm max over temp internal reference; ext. ref. input

Phase Noise @ F (Hz) >	100	1K	10K	100K	1M
dBC/Hz	-60	-70	-80	-90	-100

10 MHz level +3 dBm, ± 3 dB, 75 ohms, External In or Internal out

Controls, Indicators

Ext 10 MHz Yellow LED, indicates external 10 MHz reference selected (rear panel DPDT switch)
 PLL Alarm Red LED, External contact closure
 Power Green LED

Other

RF Connector 2.92mm (female), 50Ω
 L-Band Connector BNC (female), 50Ω
 10 MHz connectors BNC (female), 75Ω, works with 50 or 75 ohms
 Alarm Connector DB9 - NO or NC contact closure on Alarm
 Size 19 inch standard chassis 1.75" high X 14.0" deep
 Power 100-240 ±10% VAC, 47 - 63 Hz, 25 watts max.

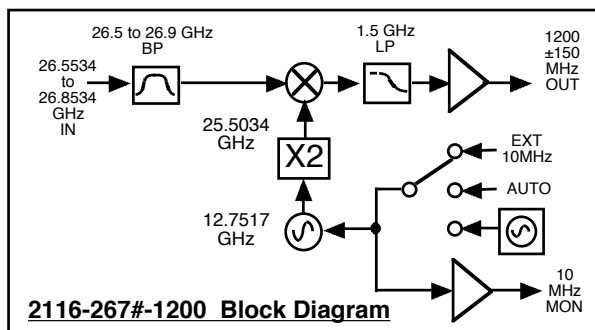

2116-267#-1200 Block Diagram

Available Options

W71 - IF Monitor Port (-20 dB, Front)
 W31 - Ext. Temp 0C to +50C

Available Connector Options-

S27 - 50Ω 2.92mm (RF), 75Ω BNC (L-BAND)
 S2F - 50Ω 2.92mm(RF), 75Ω F-type (L-BAND)
 S2N - 50Ω 2.92mm(RF), 50Ω N-type (L-BAND)
 S2S - 50Ω 2.92mm (RF), 50Ω SMA (L-BAND)

Contact Cross for other options

*+10 to +40 degrees C; Specifications subject to change without notice